

Brick Light with PureLED

PROJECT:
TYPE:
SOURCE:
NOTES:

SPECIFICATIONS

LED Chip	x4 Cree XHP-50 Plug and Play field replaceable LED board
Luminaire Output*	260 total lumens @ 350mA (8.4 watts) delivered from the luminaire with unobstructed beam
CRI (3000K)	90+
Colour Temperatures	2700K, 3000K, 4000K
Beam Angles	Asymmetric wash
Ingress Protection	IP66
Warranty	Electronics = 5 years Aluminium components = 5 years Solid Bronze components = 10 years Stainless Steel components = 10 years

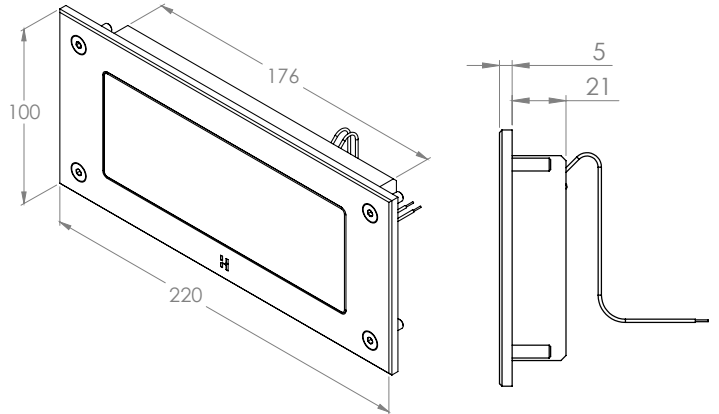

Custom designed face plate available upon request

PRODUCT CONFIGURATION

Luminaire	Power	Material/Finish	Colour Temp	Accessories	
BRK/L					
S	350mA Input, Series Wired, 8.4W	ALUMINIUM	2	CJK	
D24	24VDC Input, Parallel Wired, 8.4W		EBK	2700K	Cable Joint Kit
			EBZ	3000K	
			EOGR	4000K	BRKLENSF
			EWH		Frosted Lens
			EWB		
			EDG		
			ESTAR		
			ECT		
			FS		
		SBZ			
		SS			

S - Series Remote Driver
Power Supply: Line/Mains input to 350mA Constant Current Driver REQUIRED - NOT SUPPLIED
Fixture Input: 24Vf @ 350mA constant current maximum, 8.4W total
Wiring Method: Series

D24 - 24VDC Integral Driver
Power Supply: Line/Mains input to 24VDC Constant Voltage Power Supply REQUIRED - NOT SUPPLIED
Fixture Input: 24VDC constant voltage, 8.4W total
Wiring Method: Parallel

Additional Comments:

*Due to continued product enhancements, specifications may change without notification.

LUMINAIRE CONSTRUCTION

CNC machined from one of the following metals:

Aluminium:

High corrosion resistant aluminium with chromate substrate and high UV resistant polyester powder coat.

Body: 80mm (3 1/8") x 25mm (1") solid flat bar.

Flange: Laser cut 5mm (1/4") sheet.

Colours: Black, Bronze, Olive Green, White, White Birch, Dark Grey, Silver Star, Corten, Fine Silver.

Solid Bronze:

High quality LG2 bronze with modified lead range, high corrosion resistance and not subject to dezincification.

Flange: Laser cut 5mm (1/4") sheet.

316 Stainless Steel:

Marine Grade Stainless Steel with high corrosion resistance and superior resistance against rust and abrasion.

Flange: Laser cut 5mm (1/4") sheet.

Gaskets:

Silicone, iron impregnated 220°C (428°F).

Lens:

10mm (3/8") extra clear, low iron, shatter resistant glass. Lifetime warranty.

Mounting:

Designed to be mounted in a 176mm (7") x 80mm (3 1/8") recess and fixed in place with four stainless steel screws.

Luminaire Weight:

1.05kg (2.3lb)

BEAM ANGLE

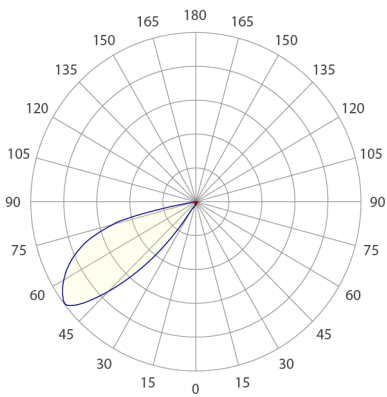

ASYMMETRIC

WIRING GUIDE

Available for download: hunzalighting.com/downloads

NOTE: Diagrams are a guide only, wire colours and polarity may change depending on fixture and country.

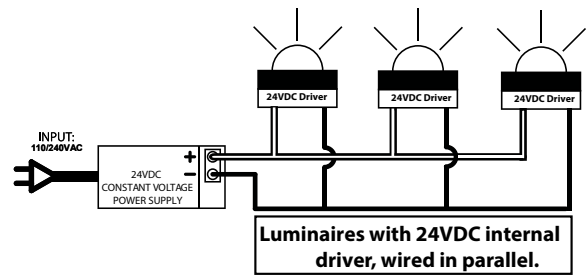
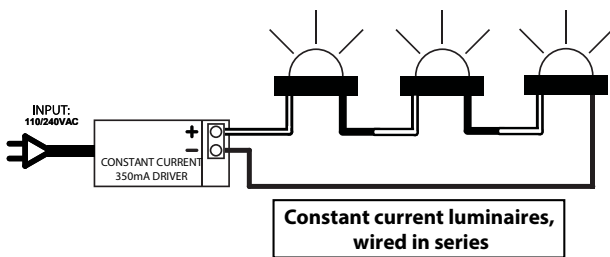

*Due to continued product enhancements, specifications may change without notification.