

Brick Light Surface Mount with PureLED

PROJECT:
TYPE:
SOURCE:
NOTES:

SPECIFICATIONS

LED Chip	x4 Cree XHP-50 Plug and Play field replaceable LED board
Luminaire Output*	260 total lumens @ 350mA (8.4 watts) delivered from the luminaire with unobstructed beam
CRI (3000K)	90+
Colour Temperatures	2700K, 3000K, 4000K
Beam Angles	Asymmetric wash
Ingress Protection	IP66
Warranty	Electronics = 5 years Aluminium components = 5 years Solid Bronze components = 10 years Stainless Steel components = 10 years

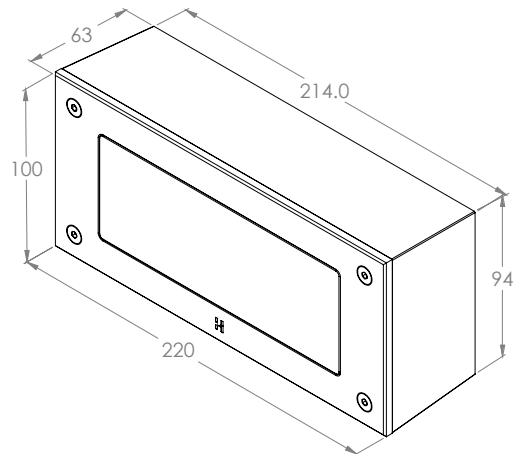

Custom designed face plate available upon request

PRODUCT CONFIGURATION

Luminaire	Power	Material/Finish	Colour Temp	Accessories	
BRKSM/L					
S	350mA Input, Series Wired, 8.4W	ALUMINIUM	2	CJK	
D24	24VDC Input, Parallel Wired, 8.4W		EBK	2700K	Cable Joint Kit
			EBZ	3000K	
			EOGR	4000K	BRKLENSF
			EWH		Frosted Lens
			EWB		
			EDG		
			ESTAR		
			ECT		
			FS		
S - Series Remote Driver Power Supply: Line/Mains input to 350mA Constant Current Driver REQUIRED - NOT SUPPLIED Fixture Input: 24Vf @ 350mA constant current maximum, 8.4W total Wiring Method: Series					
D24 - 24VDC Integral Driver Power Supply: Line/Mains input to 24VDC Constant Voltage Power Supply REQUIRED - NOT SUPPLIED Fixture Input: 24VDC constant voltage, 8.4W total Wiring Method: Parallel					
		SBZ			
		SS			

Additional Comments:

*Due to continued product enhancements, specifications may change without notification.

LUMINAIRE CONSTRUCTION

CNC machined from one of the following metals:

Aluminium:

High corrosion resistant aluminium with chromate substrate and high UV resistant polyester powder coat.

Body: 80mm (3 1/8") x 25mm (1") solid flat bar.

Flange: Laser cut 5mm (1/4") sheet.

Surface Mount Canister: Sand cast 220mm (5 5/8") x 100mm (4") x 58mm (2 1/4") box.

Colours: Black, Bronze, Olive Green, White, White Birch, Dark Grey, Silver Star, Corten, Fine Silver.

Solid Bronze:

High quality LG2 bronze with modified lead range, high corrosion resistance and not subject to dezincification.

Flange: Laser cut 5mm (1/4") sheet.

316 Stainless Steel:

Marine Grade Stainless Steel with high corrosion resistance and superior resistance against rust and abrasion.

Flange: Laser cut 5mm (1/4") sheet.

Gaskets:

Silicone, iron impregnated 220°C (428°F).

Lens:

10mm (3/8") extra clear, low iron, shatter resistant glass. Lifetime warranty.

Mounting:

The Surface Mount Canister is designed for mounting onto flat vertical surfaces. It is anchored via four self tapping screws through the back of the canister. The luminaire is then installed into the canister with four stainless steel screws.

Luminaire Weight:

1.05kg (2.3lb)

BEAM ANGLE

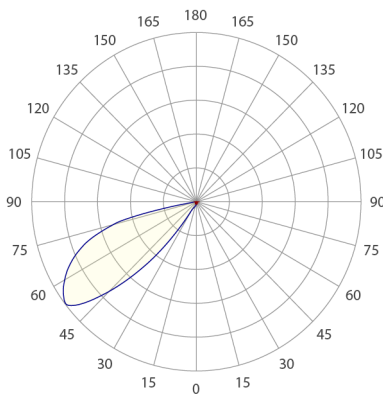

ASYMMETRIC

WIRING GUIDE

NOTE: Diagrams are a guide only, wire colours and polarity may change depending on fixture and country.

Available for download: hunzalighting.com/downloads

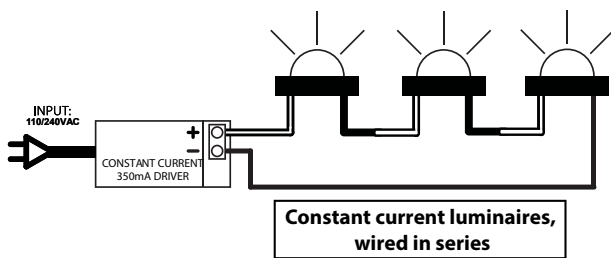

Constant current luminaires, wired in series

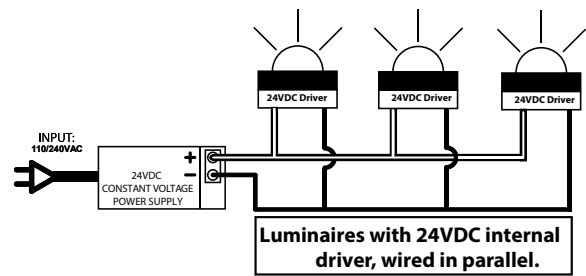

Luminaires with 24VDC internal driver, wired in parallel.

*Due to continued product enhancements, specifications may change without notification.