

## Brick Light with Recessed Canister with PureLED

PROJECT:
TYPE:
SOURCE:
NOTES:

### SPECIFICATIONS

LED Chip	x4 Cree XHP-50 Plug and Play field replaceable LED board
Luminaire Output*	260 total lumens @ 350mA (8.4 watts) delivered from the luminaire with unobstructed beam
CRI (3000K)	90+
Colour Temperatures	2700K, 3000K, 4000K
Beam Angles	Asymmetric wash
Ingress Protection	IP66
Warranty	Electronics = 5 years Aluminium components = 5 years Solid Bronze components = 10 years Stainless Steel components = 10 years

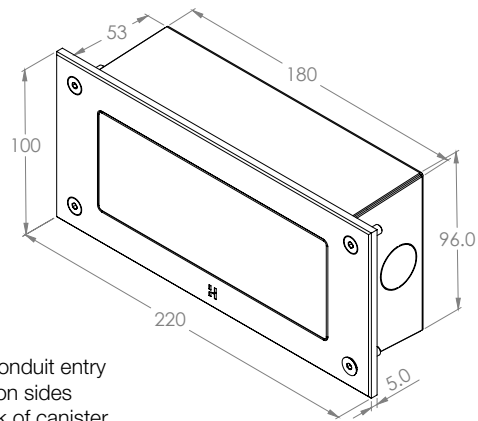

25mm conduit entry options on sides and back of canister

Custom designed face plate available upon request

### PRODUCT CONFIGURATION

Luminaire	Power	Material/Finish	Colour Temp	Accessories	
BRKRC/L					
S	350mA Input, Series Wired, 8.4W	ALUMINIUM	2	CJK	
D24	24VDC Input, Parallel Wired, 8.4W		EBK	2700K	Cable Joint Kit
			EBZ	3000K	
			EOGR	4000K	BRKLENSF
			EWH		Frosted Lens
			EWB		
			EDG		
			ESTAR		
			ECT		
			FS		
		SBZ			
		SS			

Additional Comments:

\*Due to continued product enhancements, specifications may change without notification.

# LUMINAIRE CONSTRUCTION

**CNC machined from one of the following metals:**

**Aluminium:**

High corrosion resistant aluminium with chromate substrate and high UV resistant polyester powder coat.

Body: 80mm (3 1/8") x 25mm (1") solid flat bar.

Flange: Laser cut 5mm (1/4") sheet.

Colours: Black, Bronze, Olive Green, White, White Birch, Dark Grey, Silver Star, Corten, Fine Silver.

**Solid Bronze:**

High quality LG2 bronze with modified lead range, high corrosion resistance and not subject to dezincification.

Flange: Laser cut 5mm (1/4") sheet.

**316 Stainless Steel:**

Marine Grade Stainless Steel with high corrosion resistance and superior resistance against rust and abrasion.

Flange: Laser cut 5mm (1/4") sheet.

Recessed Canister: Laser cut and folded 1mm (1/16") sheet.

**Gaskets:**

Silicone, iron impregnated 220°C (428°F).

**Lens:**

10mm (3/8") extra clear, low iron, shatter resistant glass. Lifetime warranty.

**Mounting:**

The recessed canister is designed for casting into concrete to facilitate ease of installation. The luminaire is then fixed in place with four stainless steel screws.

**Luminaire Weight:**

1.05kg (2.3lb)

# BEAM ANGLE

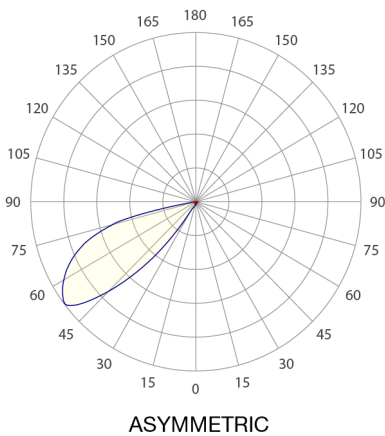

# WIRING GUIDE

Available for download: [hunzalighting.com/downloads](http://hunzalighting.com/downloads)

**NOTE:** Diagrams are a guide only, wire colours and polarity may change depending on fixture and country.

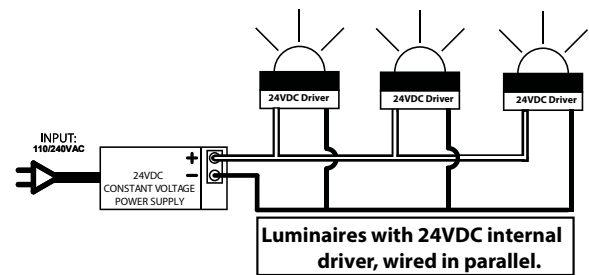
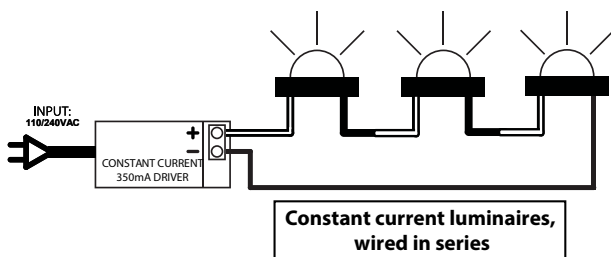

\*Due to continued product enhancements, specifications may change without notification.